

TECHNICKÉ ÚDAJE

TYPE	SJER-K2 250/2,5	
CODE		
CAPACITY (WLL)	Q(kg)	250
THEORETICAL RANGE	L(mm)	2500
ROTATION RANGE	ALFA (°)	310
TOTAL HEIGHT	Hc(mm)	3 132
SUSPENSION HEIGHT	HS (mm)	3098
TYPE HOIST	YALE VS	250
DEAD HOIST	G (kg)	9
DEAD WEIGHT	Gj (kg)	210

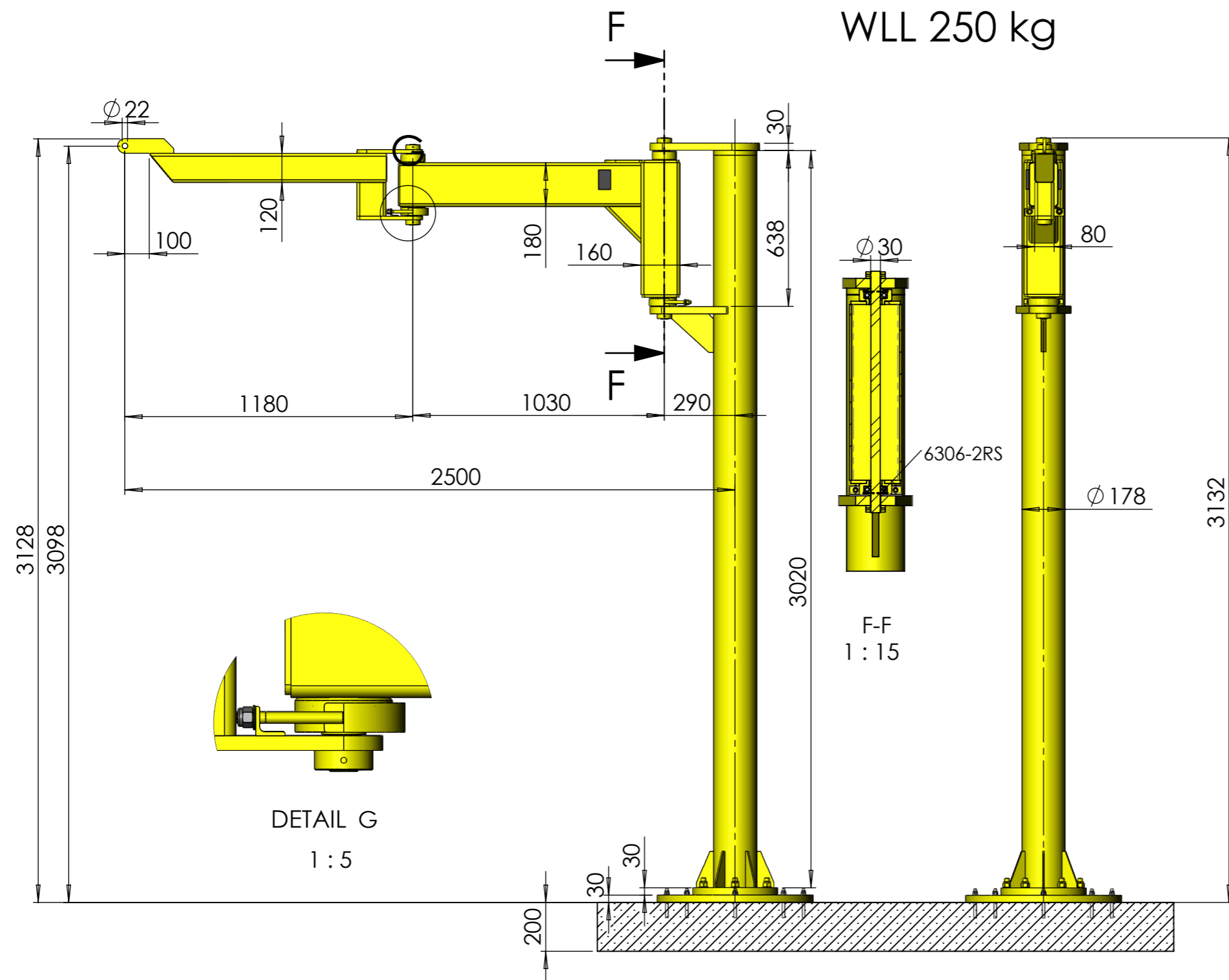

CONFIRMATION BY PURCHASER

We confirm, that we agree with this project.

Datum: _____

Company: _____

Name: _____

Signature: _____

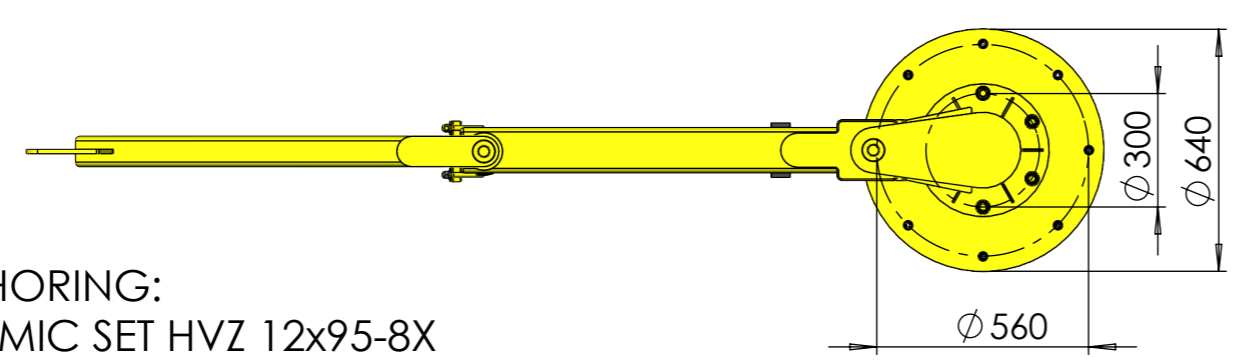

TYPE ANCHORING:
 HILTI DYNAMIC SET HVZ 12x95-8X
 DRILLING DEPTH: 110 MM
 THICKNESS OF BASE MATERIAL: 200 MM

Customer :		Ident.Nr.:	
Name :	KRANE -SJER-K2		
Type :	SJER-K2 250/2,5		
Drawed by:	Václav Hájek		
Authorized :	Emil Čuhel		
Nr.of Drawing	021J43-000		

